

# Calibre Bath mixer system with hand shower 150mm

# SUSSEX

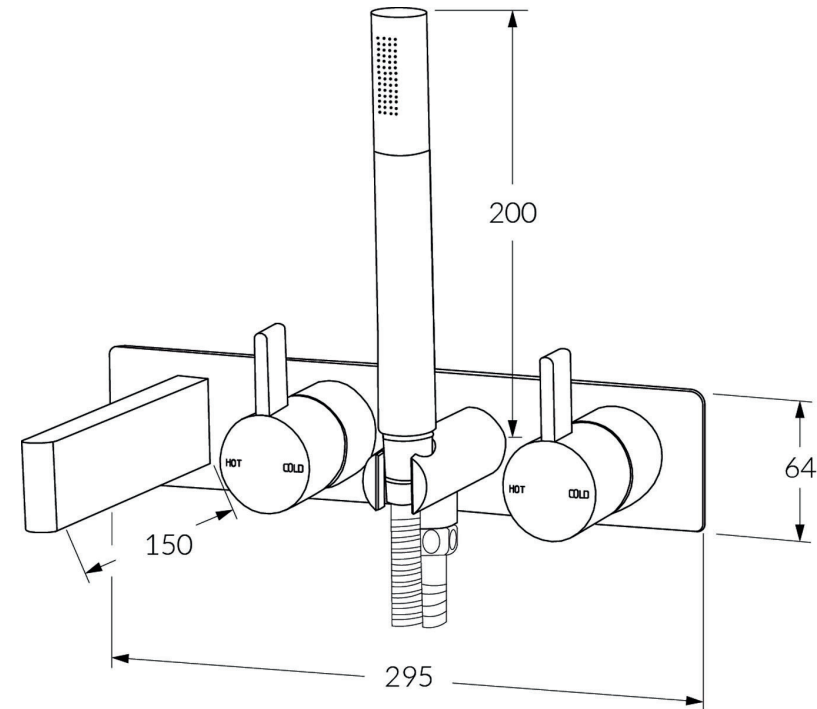

## Product code

CBMS150RH

## Product features

- Designed and manufactured in Australia
- All brass construction
- Fixed handle lever
- 35mm ceramic disc cartridge
- Incorporating Sussex Masterfit
- Available in a range of high quality, durable finishes inc. LUXPVD®
- Minimal, refined design to complement any contemporary space
- Matching tapware and showers

## Warranty

15 Years  
Shower head and arm.  
3 years for rail showers.  
2 years for shower hoses.

## Pressure rating

300 - 500kPa

## Temperature rating

1 - 65°C

## WELS rating

3 star - 8.5lt/min



AS/NZS 3718:2005  
LIC. 20081



While we aim to ensure the specifications shown are correct at time of printing, Sussex Taps reserves the right to make modifications without prior notice. Always use the physical product for accurate measurements. Dimensions are subject to change without notice. All measurements are shown in millimetres.

Copyright © Sussex Taps