

Scala Mini Sink/basin mixer

SUSSEX

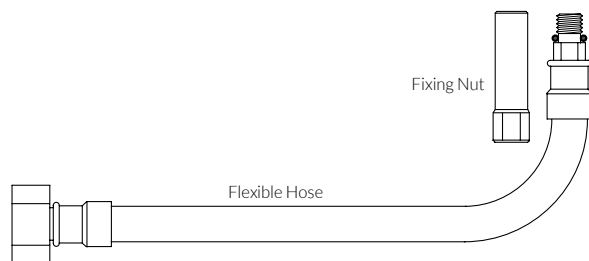
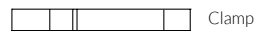
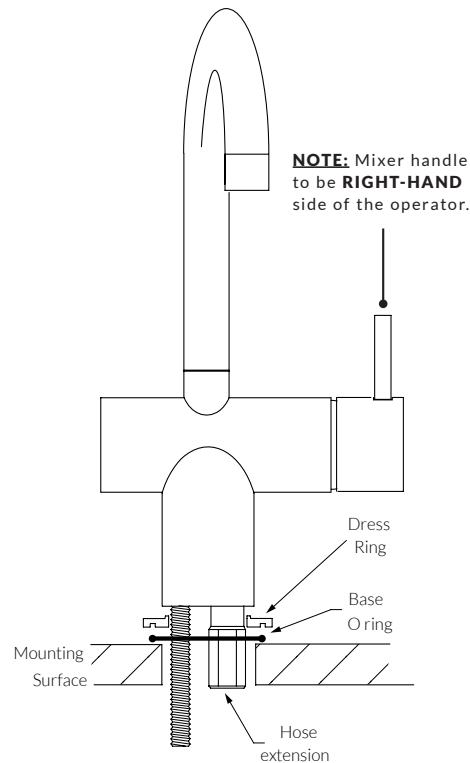

Product code

SLSMCLRH	Sink mixer curved large	SLSMQLRH	Sink mixer square large
SLSMCSRH	Basin/sink mixer curved small	SLSMQSRH	Basin/sink mixer square small

Installation guidelines

- The Mixer will be supplied assembled and will require some parts to be removed prior to installing.
- Remove the Fixing Nut and Clamp from the Mixer.
- Hose extensions are factory fitted and sealed. They should not be removed!
- Attach the supplied Flexible Hoses to the Mixer. In some cases the Flexible Hoses may need to feed up through the mounting surface and then attached to the Mixer.
- Working from underneath the mounting surface fit clamp and secure the mixer with the Fixing Nut. Ensure that the Base O Ring is in position and the Mixer is properly centered over the clearance hole of the mounting surface.
- Connect 1/2" BSP female fittings of the Flexible tails to the corresponding Hot and Cold water lines.
- Isolating stop cocks are recommended with all installations (Not Supplied).
- Once the Mixer is secured test the Mixer for correct function and water flow.
- Check for any leaks and ensure all surfaces are water-tight.

Note: The clearance hole size for mounting mixer to between 32 -35mm.

Plumber note

- On-site testing using higher water pressures must be conducted with the Mixer in the closed position. (STATIC TEST)
- Under no circumstances is the Mixer to be opened when exceeding the maximum stated water pressure.
- At the completion of testing, do not relieve any high water pressure by operating the Mixer.
- Exposing the internals of the Mixer Cartridge to higher than specified water pressures will void the manufacturers warranty.