

Scala Mini Basin mixer

SUSSEX

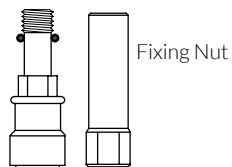
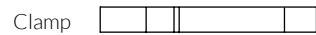
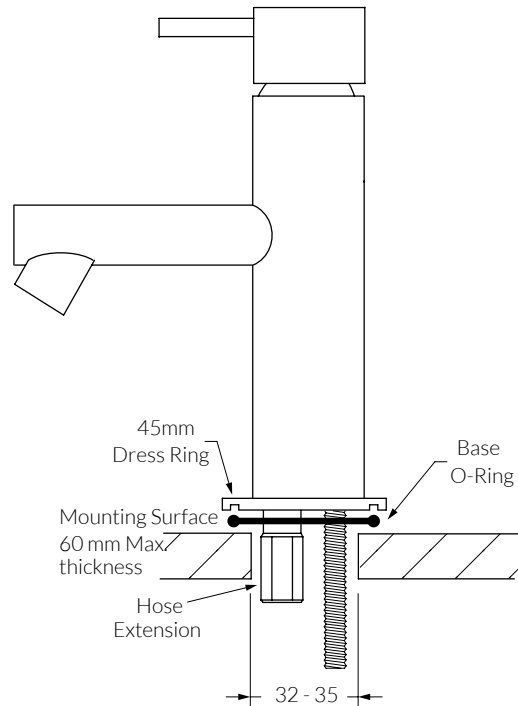

Product code

SLBM	Basin mixer
SLEBM	Extended basin mixer

Installation guidelines

- The Mixer will be supplied assembled and will require some parts to be removed prior to installing.
- The diagram illustrates the parts that need to be separated.
- Hose extensions are factory fitted and sealed. They should not be removed!
- First attach the Flexible Hoses to the Mixer.
- In some cases the Flexible Hoses may need to feed up through the mounting surface and then attached to the Mixer.
- Working from underneath the mounting surface fit clamp and secure the mixer with the Fixing Nut, ensuring at all times that the Base O Ring is in position and the Mixer is properly centered over the hole in the mounting surface.
- Connect Hot and Cold Flexible tail to the corresponding 1/2" BSP male threaded fittings. (Not Supplied)
- Isolating stop cocks are recommended with all installations. (Not Supplied)
- Check for any leaks and ensure all surfaces are water-tight.

Note: The clearance hole size for mounting mixer to be between 32 -35mm

Plumber note

- On-site testing using higher water pressures must be conducted with the Mixer in the closed position. (STATIC TEST)
- Under no circumstances is the Mixer to be opened when exceeding the maximum stated water pressure.
- At the completion of testing, do not relieve any high water pressure by operating the Mixer.
- Exposing the internals of the Mixer Cartridge to higher than specified water pressures will void the manufacturers warranty.