

# Voda

## Floormount mixer Fixing distances

# SUSSEX

### Product code

VFMT	Floormount mixer 160mm	VFMHT	Floormount mixer with hand held
VFM200T	Floormount mixer 200mm	VFMMCT	Floormount mixer with curved outlet
VFM250T	Floormount mixer 250mm	VFMBMCT	Floormount basin mixer curved

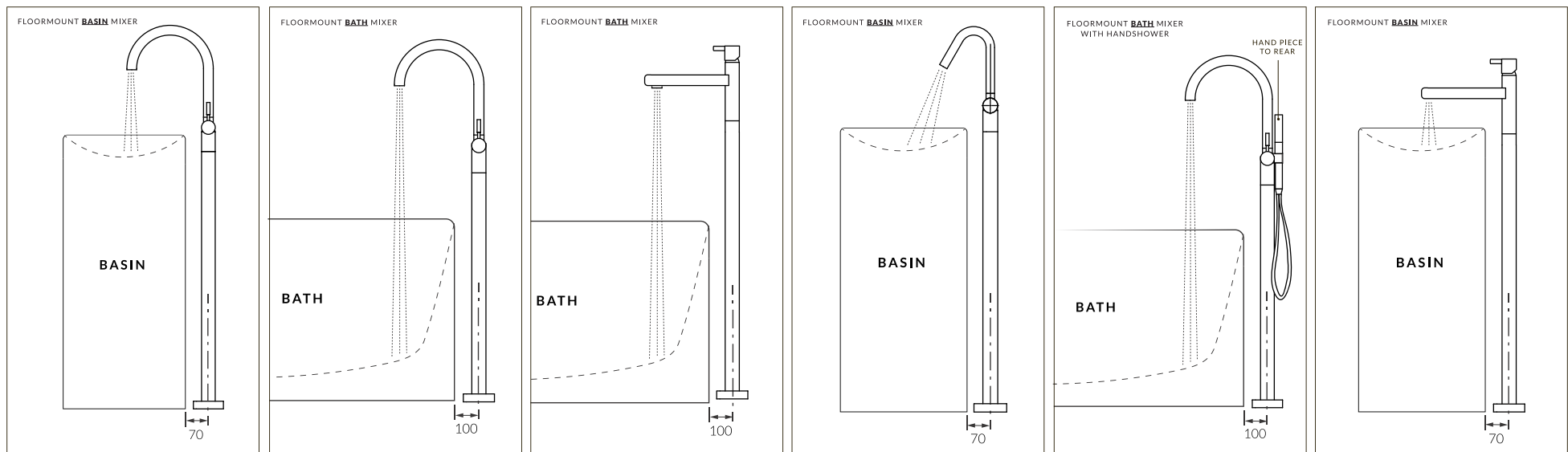

# Voda Floormount mixer Concrete floor Rough-in

SUSSEX

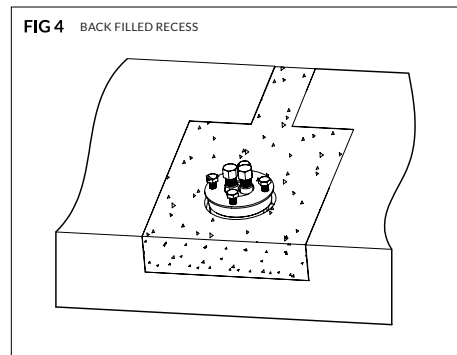
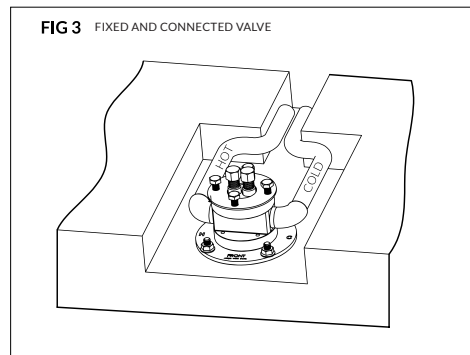
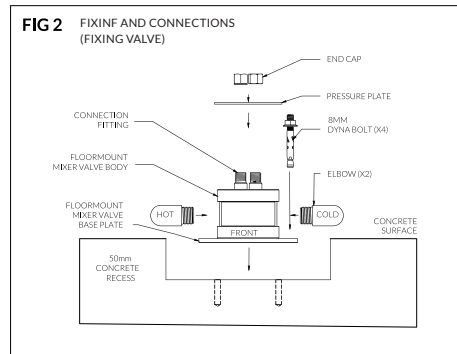
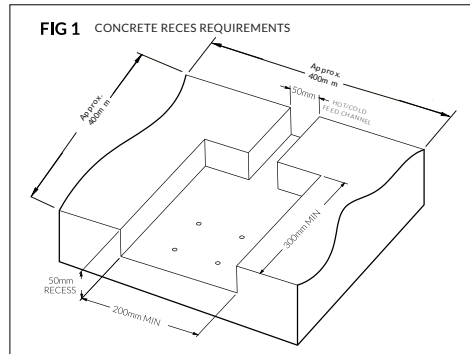

\*To install this floormount fixing valve, a 50mm step down (recess) is required in the concrete slab. The floormount fixing valve is supplied with end caps, pressure plate and fixing bolts. Leave intact until final fit off with the floormount mixer.

## New concrete floor (pre-pour)

\*To install the Floormount Fixing Valve a 50mm step down (recess) is required in the concrete surface where the floormount is to be located.

- The recess area is to be a minimum of 200 x 300mm to allow enough room for the fixing valve to be fitted.

**NOTE:** This can be a larger area if unsure of exact mounting position.

**Important:** the recess area is required to be 50mm deep and must be flat and level.

## Existing concrete floor

- Cut 400 x 400mm section through concrete slab where the floormount mixer is to be located (Fig. 1).
- Remove cut section and drill for the appropriate concrete 'tie-rods' into side walls of cavity.
- Fit 'tie-rods' and pour concrete to create a 50mm step down (recess) from the original concrete floor surface (Fig. 1).

**NOTE:** Recess area must be flat and level.

- Hot and cold lines can be chased into the recessed area by cutting a minimum 50 x 50mm channel (Fig. 1).

## Fixing and connections (Fig. 2 & 3)

- Connect 1/2" elbows (or male/female nipples) to Fixing Valve in preparation for the hot/cold water lines.
- Position fixing valve into concreted recess area.

**NOTE:** Align "Front" to face bath or wash vessel.

- Mark and drill for 8mm "dyna bolt" or other appropriate anchoring bolts (not supplied).
- Fix Floormount Fixing Valve and complete hot and cold water line connections.
- Ensure the valve is level and well anchored.
- Tighten "end caps" and perform water testing, and ensure there are no water leaks.
- Leave end caps, pressure plate and fixing bolts in the valve to protect the threads until final fit-off.

## Back-filled recess (Fig. 4)

- Once all water connections are made and tested, fill in the recessed area and channelling up to the Fixing Valve with a mortar mix.
- After mortar has set, seal the area between mortar and the Fixing Valve.

# Voda Floormount mixer Wooden floor Rough-in

SUSSEX

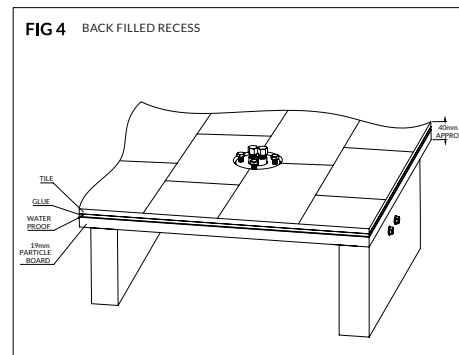
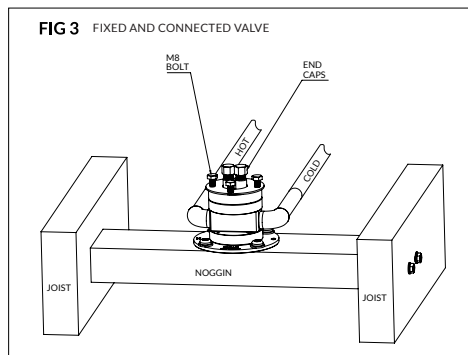
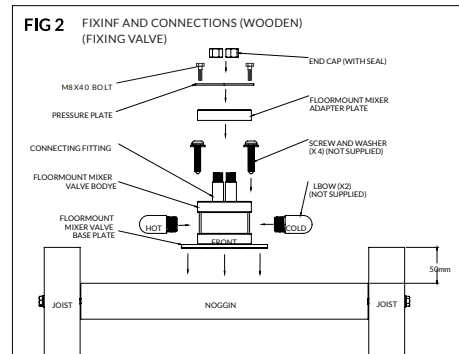
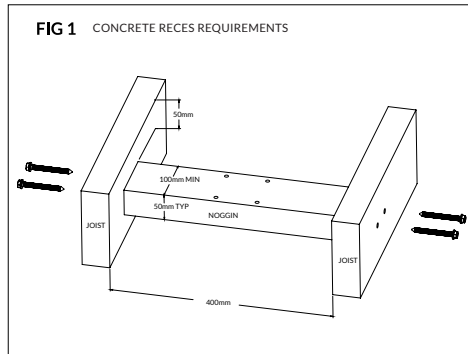

## Rough-in (Wooden floor)

- Fix a 100x50mm min noggin. 50mm below the top of the joists in the position where the floormount mixer is to be located (Fig. 1).

**NOTE:** the floormount mixer has been supplied to suit a concrete installation. Some parts need to be changed to suit a wooden floor.

- To suit wooden flooring, remove the m8x25mm bolts and the pressure plate. Using a 6mm allen key, remove the two connection fittings (O-ring sealed) and replace with the longer version (tighten well).
- Add the Floormount Mixer Adapted Plate. Replace the Pressure Plate and loosely fit the M8x40mm bolts (Fig. 2).
- Add appropriate elbows or 1/2" BSP nipples to allow for hot/cold water connections (not supplied).
- Secure Floormount Mixer Valve to noggin using appropriate wood screws (not supplied).

**NOTE:** "FRONT" to face water vessel.

- Complete hot/cold water connections.
- Ensure the valve is level and well anchored.

## Fixing and connections (Fig. 2 & 3)

- Connect 1/2" elbows (or male/female nipples) to Fixing Valve in preparation for the hot/cold water lines.
- Position fixing valve into concreted recess area.

**NOTE:** Align "Front" to face bath or wash vessel.

- Mark and drill for 8mm "dyna bolt" or other appropriate anchoring bolts (not supplied).
- Fix Floormount Fixing Valve and complete hot and cold water line connections.
- Ensure the valve is level and well anchored.
- Tighten "end caps" and perform water testing, and ensure there are no water leaks.
- Leave end caps, pressure plate and fixing bolts in the valve to protect the threads until final fit-off.

## Back-filled recess (Fig. 4)

- Once all water connections are made and tested, fill in the recessed area and channelling up to the Fixing Valve with a mortar mix.
- After mortar has set, seal the area between mortar and the Fixing Valve.

# Voda Floormount mixer Concrete floor Fit-off

SUSSEX

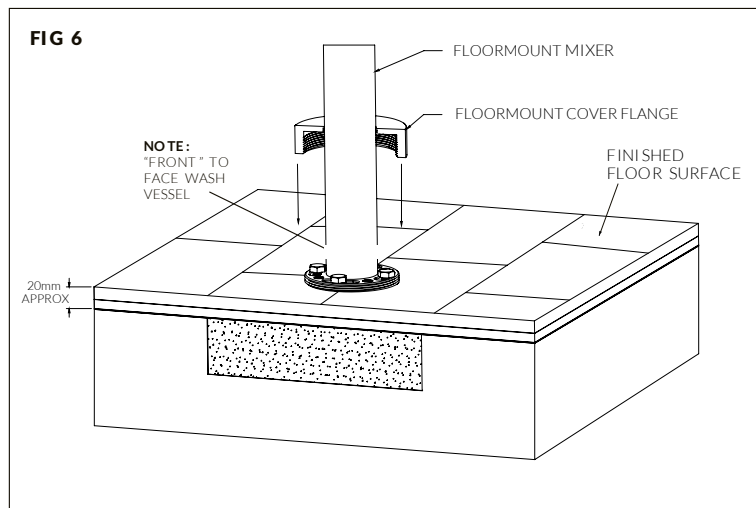
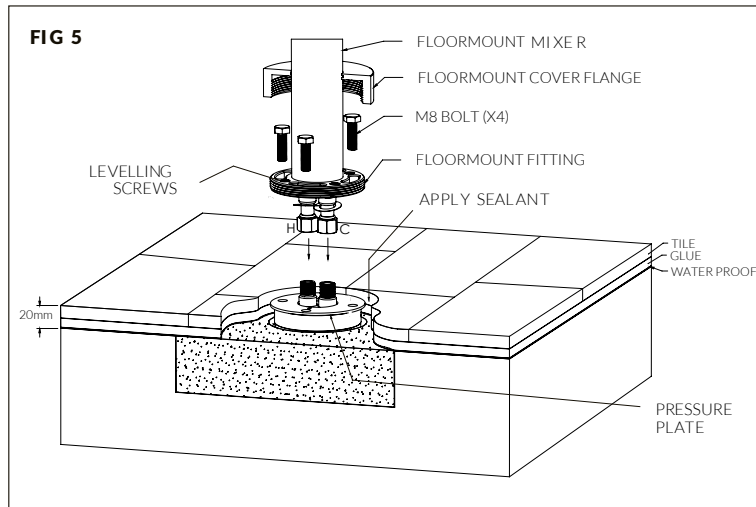

## Fit-off (Concrete floor)

- Prior to installing, ensure floor around fixing valve is completely sealed.
- Raise the floormount cover flange.
- Remove "end caps" and retain if required.
- Connect hot and cold hoses from Floormount Mixer (a second person may be required to assist).
- NOTE:** the hose connection has a self sealing fitting. No sealant is required.
- Tighten the hex nuts of the hose fittings using an appropriate spanner (tighten well).
- Carefully lower the mixer to meet the pressure plate.
- NOTE:** "Front" of Floormount Mixer must face the bath or wash vessel.
- Align and fit supplied M8 bolts.
- Before fully tightening, allow water flow and check for water leaks.
- Tighten M8 bolts and check Floormount Mixer is level. If levelling is required, loosen M8 bolts and adjust levelling screws as required.
- To complete the installation, lower the cover flange until it meets the finished floor surface.
- Check mixer function and look for any leaks.

# Voda Floormount mixer Wooden floor Fit-off

SUSSEX

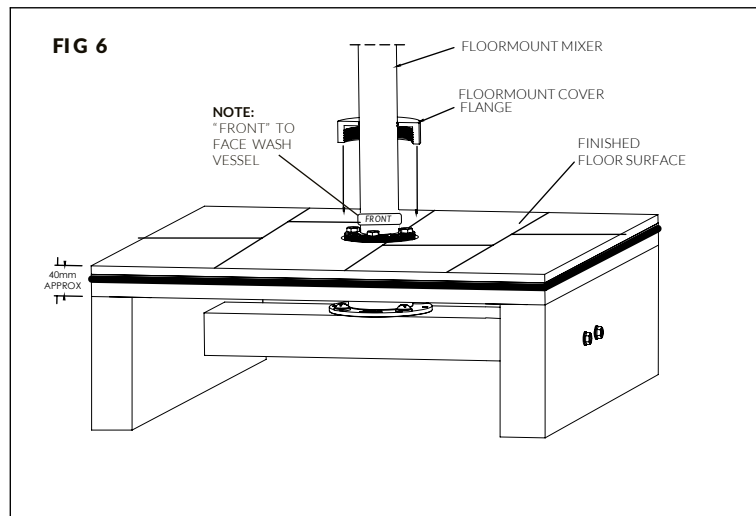
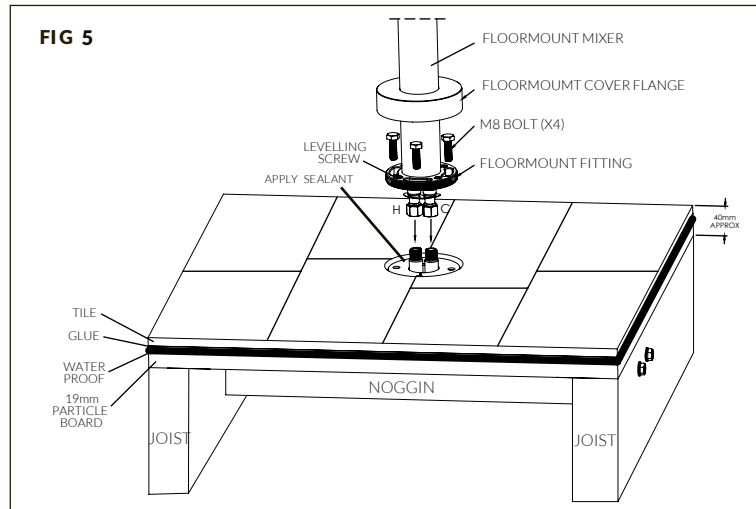

## Fit-off (Wooden floor)

- Prior to installing, ensure floor around fixing valve is completely sealed.
  - Raise the floormount cover flange.
  - Remove "end caps" and retain if required.
  - Connect hot and cold hoses from Floormount Mixer (a second person may be required to assist).
- NOTE:** the hose connection has a self sealing fitting. No sealant is required.
- Tighten the hex nuts of the hose fittings using an appropriate spanner (tighten well).
  - Carefully lower the mixer to meet the pressure plate.
- NOTE:** "Front" of Floormount Mixer must face the bath or wash vessel.
- Align and fit supplied M8 bolts.
  - Before fully tightening, allow water flow and check for water leaks.
  - Tighten M8 bolts and check Floormount Mixer is level. If levelling is required, loosen M8 bolts and adjust levelling screws as required.
  - To complete the installation, lower the cover flange until it meets the finished floor surface.
  - Check mixer function and look for any leaks.

# Voda Floormount mixer Installation kit Fit-off

# SUSSEX

