

# Pure Basin Mixer Curved

SUSSEX

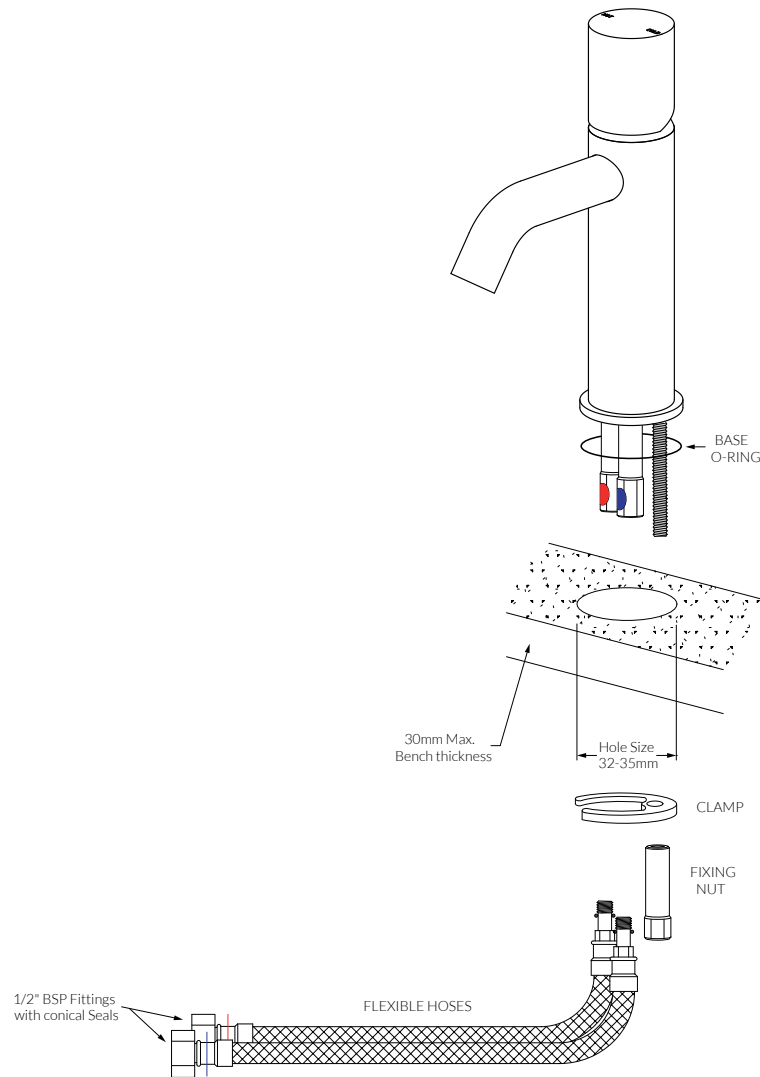

reece™

www.reece.com.au

## Product codes:

MPBMC.01  
MPEBMC.01  
MPMBMC.01

## Install Preparation:

- Surface clearance hole size to be between 32 - 35mm.
- Maximum Bench/Hob thickness is 30mm.

## Install:

- The Mixer is supplied assembled, only the Fixing nut and the Clamp need to be removed.
- After removing the mentioned parts, lower the Mixer on to the mounting surface and fit the Flexible Hoses.
- In some cases the Flexible Hoses may need to be fed through from under the mounting surface and then attached. (Tighten using appropriate spanner)
- After securing the Flexible Hoses, fit Clamp and attach the Fixing Nut from underneath.
- Before fully securing the Mixer ensure that the Base O Ring is intact and the Mixer is properly centered over the mounting surface hole.
- The Mixer mounting surface must be completely sealed and water-tight.
- The 1/2" Fittings of the Flexible Hoses have a conical seal, ensure that the matching threads are cut square and burr free. - Prior to connecting the Flexible Hoses, ensure all pipework is thoroughly flushed and free of any dirt or debris.
- Isolating Stop Valves are recommended with all installations. (not supplied)
- Connect the Flexible Hoses to Hot and Cold pipework fittings, ensure the Hoses do not kink or become twisted when tightening. Check all fittings and connections are secure and water-tight.

## Plumbers note:

- Tapware is to be installed by a Licensed Plumber in accordance with AS/NZS 3500:2021
- Recommended working water pressure 300 - 500 Kpa. Maximum water temperature is 65°C

**W**  
Lead Free  
AS 3718  
LIC. 20081

While we aim to ensure the specifications shown are correct at time of printing, Sussex Taps reserves the right to make modifications without prior notice. Always use the physical product for accurate measurements. Dimensions are subject to change without notice. All measurements are shown in millimetres. This product complies with lead free requirements.

Copyright © Sussex Taps