

Suba Lever Top mount hob mixer

SUSSEX

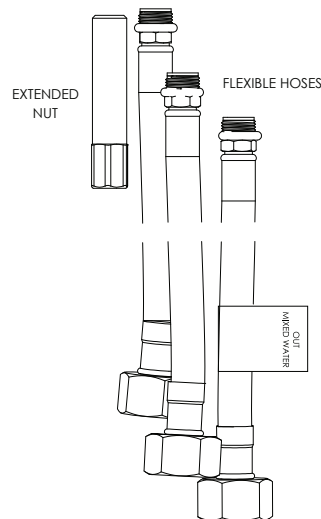
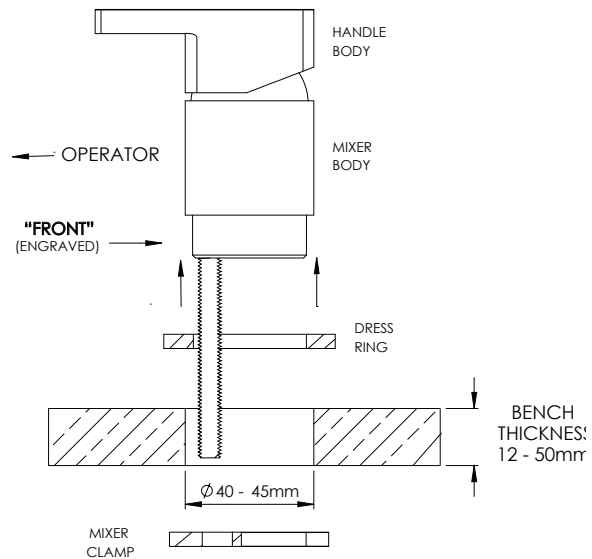

Product code

BLTMHM Top mount hob mixer

Installation guidelines

- Mixer clearance hole in mounting surface is to be between 40-45mm.
- Bench thickness 12-50mm.
- Remove ext. nut and mixer clamp from mixer body and fit dress ring.
- Attach hot and cold flexible hoses as marked on mixer body. Also attach the "Out Mixed Water" flexible hose to the position marked 'OUT'.
- Lower the mixer on to the mounting surface.

Note: The "FRONT" engraved on mixer body must be positioned facing the operator.

- Working from the underside, fit mixer clamp and fix the mixer using the ext. nut (tighten well).
- Connect the flexible hoses to hot and cold lines.
- Connect "out" mixed water flexible hose to Outlet/ Spout.
- After mixer is secured and connections are made, check function and inspect for any leaks.

Plumber note

- On-site testing using higher water pressures must be conducted with the Mixer in the closed position. (STATIC TEST)
- Under no circumstances is the Mixer to be opened when exceeding the maximum stated water pressure.
- At the completion of testing, do not relieve any high water pressure by operating the Mixer.
- Exposing the internals of the Mixer Cartridge to higher than specified water pressures will void the manufacturers warranty.