

Scala Wall top assembly

SUSSEX

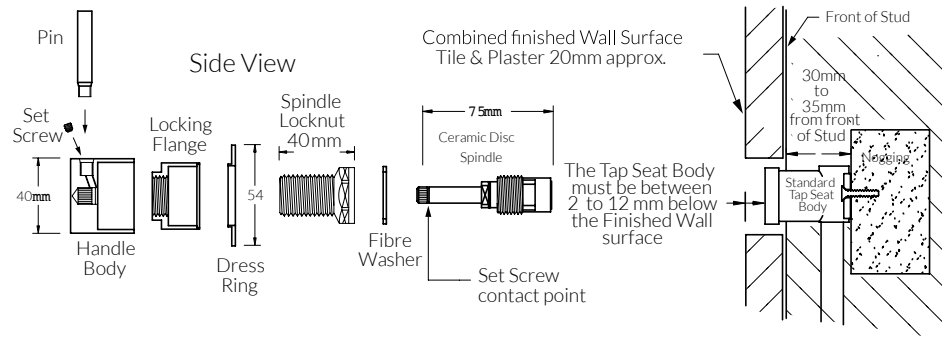

Rough in (new wall breach)

- A standard Wall Breach (not supplied) is to be used in conjunction with this Tapware.
- Prepare a nogging to be fitted 32 - 35mm back from the front of the stud for the fixing of the Wall Breach (as shown).
- When fixing the Breach to the nogging; ensure the Tap seats of the Breach will be level and square to the Finished Wall.
- To ensure the Tapware will fit correctly the thickness of the finished wall coverings must be calculated prior to "Rough In".
- When using thicker than normal wall covering, position the breach as forward as possible to ensure the Tapware will fit.

Using existing breach (changing tapware only)

- Remove the old Spindles and clean surrounding area.
- When installing new Spindles into old Breaching, it is highly recommended to use a re-seating tool to dress the Seat.
- Ensure the Spindle Seat is clean, flat and free of any debris.
- All lines must be completely flushed prior to fitting the Spindles.
- The distance from the finished Wall surface to the top of the Tap Seat must be between 2 to 12mm (See diagram)
- If the installation configuration is not with-in the dimensions as shown, alternative Spindles are available.

Longer Spindles can be ordered from original place of purchase. Sussex Part No. SXSPK (12mm longer than standard)

Note: Seat or Breach Body extensions are NOT to be used in conjunction with this Tapware. Failure to adhere will void warranty.

Product code

SWT	Wall top assembly
SWTASS	Wall top assembly 316 SS

Fitting off

- Upon receiving, carefully unpack the Tapware; note some parts have been combined for packaging purposes.
 - Separate parts as shown in diagram. The Spindles are supplied with Hot and Cold indication.
 - Install the Spindles hand-tight until the seal of the Spindle makes contact with the seat.
 - To ensure a good seal is made; tighten the Spindle slightly more using an appropriate spanner. Do not over-tighten.
- Note:** over-tightening the Spindles could damage the ceramic discs and in turn, void the manufacturer's warranty.
- Place the Fibre washer over the seated Spindle and fit the Spindle Locknut. (Tighten well).
 - Seal the wall around the Spindle, position the Dress ring and secure using the Locking Flange.
 - Fit the Handle Body, the Handle Body must be fully engaged onto the Spindle; note the Set Screw contact point (See diagram).
 - Secure the Handle body by tightening the Set screw using the 2mm Allen key provided (Tighten well).
 - Fit the Pin to the Handle Body. (NOTE: Apply a small amount of silicone or mild adhesive (Loctite) to the thread of the Handle Pin to assist in preventing the Pin from becoming loose).
 - If Handle requires fine adjustment, See Pin Alignment guide below.
 - After completing the installation, establish water supply, check function of Tapware and ensure no water leaks.

Handle/pin alignment

- The Spindle may require fine tuning to enable the correct Pin position, proceed as follows:
- Remove the Pin, Handle Body, Locking Flange and Dress Ring from the installed Tapware.
- Remove the Locknut and loosen the Spindle.
- Re-seat the Spindle hand-tight until the seat is felt.
- Fit the Pin to the Handle Body, and engage the Handle onto the Spindle.
- Using the Handle Body, tighten the Spindle slightly more until the Pin has reached the correct position.
- Do not over-tighten the Spindle.
- Replace the Fibre Washer and Locknut, tighten the Locknut using an appropriate Tube Spanner.
- Remove the Pin from the Handle Body and complete the installation as previously described.
- Repeat this procedure until the Pin alignment has been successfully achieved.