

# Scala Shower mixer/diverter system

# SUSSEX

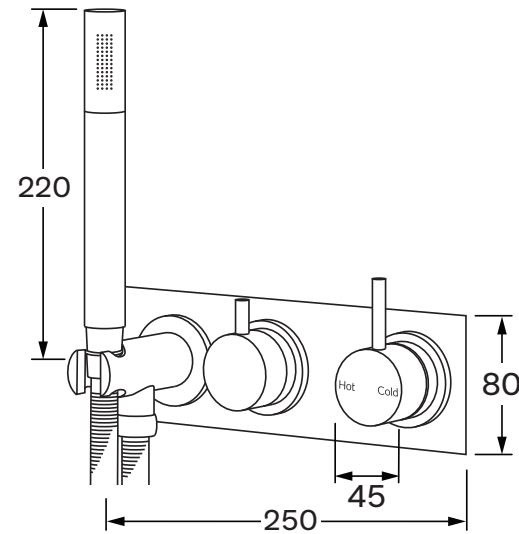

## Product code

SSDSRH

## Product features

- Designed and manufactured in Australia
- All brass construction
- 35mm ceramic disc cartridge
- Dial operating diverter
- Incorporating Sussex Masterfit
- Available in a range of high quality, durable finishes inc. LUXPVD®
- Minimal, refined design to complement any contemporary space
- Matching tapware, showers and accessories

## Warranty

15 Year overall warranty.  
Refer to Warranty sheet for specific information.

## Pressure rating

300 - 500kPa

## Temperature rating

1 - 65°C

## WELS rating

3 star - 8.5lt/min